

TM 11-6130-453-24P

TECHNICAL MANUAL

**ORGANIZATIONAL, DIRECT SUPPORT, AND
GENERAL SUPPORT MAINTENANCE
REPAIR PARTS AND SPECIAL TOOLS LIST
FOR
POWER SUPPLY PP-7545A/U (NSN 6130-01-177-0794)**

**HEADQUARTERS, DEPARTMENT OF THE ARMY
1 JANUARY 1986**

TECHNICAL MANUAL }
 No. 11-6130-453-24P }

HEADQUARTERS
 DEPARTMENT OF THE ARMY
 WASHINGTON, DC, 1 January 1986

**ORGANIZATIONAL, DIRECT SUPPORT, AND
 GENERAL SUPPORT MAINTENANCE
 REPAIR PARTS AND SPECIAL TOOLS LIST
 FOR
 POWER SUPPLY PP-7545A/U (NSN 6130-01-177-0794)
 Current as of 19 August 1985**

REPORTING ERRORS AND RECOMMENDING IMPROVEMENTS

You can help improve this manual. If you find any mistakes or if you know of a way to improve the procedures, please let us know. Mail your letter, DA Form 2028 (Recommended Changes to Publications and Blank Forms), or DA Form 2028-2 located in back of this manual direct to: Commander, US Army Communications-Electronics Command and Fort Monmouth, ATTN: AMSEL-ME-MP, Fort Monmouth, NJ 07703-5007.

In either case, a reply will be furnished direct to you.

Table of Contents

	Page	Illus Figure
SECTION I. Introduction	1	
SECTION II. Repair Parts List	1-1	
GROUP 00 Power Supply PP-7545A/U	1-1	1
01 Front Panel and Panel Assembly (See Group 00 for parts)		
SECTION III. Special Tools List (Not applicable)		
SECTION IV. National Stock Number and Part Number Index	I-1	

SECTION I

INTRODUCTION

1. Scope

This manual lists and authorizes spares and repair parts; special tools; special test, measurement, and diagnostic equipment (TMDE); and other special support equipment required for performance of organizational, direct support, and general support maintenance of the PP-7545/U. It authorizes the requisitioning, issue, and disposition of spares, repair parts and special tools as indicated by the source, maintenance and recoverability (SMR) codes.

2. General

This Repair Parts and Special Tools List is divided into the following sections:

a. Section II. Repair Parts List. A list of spares and repair parts authorized by this RPSTL for use in the performance of maintenance. The list also includes parts which must be removed for replacement of the authorized parts. Parts lists are composed of functional groups in ascending numeric sequence, with the parts in each group listed in ascending item number sequence. Figure numbers are listed directly beneath the group header.

b. Section III. Special Tools List. Not applicable.

c. Section IV. National Stock Number and Part Number Index. A list, in National item identification number (NIIN) sequence, of all National stock numbered items appearing in the listing, followed by a list in alphameric sequence of all part numbers appearing in the listings. National stock numbers and part numbers are cross-referenced to each illustration figure and item number appearance.

3. Explanation of Columns (Section II and III)

a. Item No. (Column (1)). Indicates the number used to identify items called out in the illustration.

b. SMR Code (Column (2)). The source, maintenance, and recoverability (SMR) code is a five-position code containing supply/requisitioning information, maintenance category authorization criteria, and disposition instruction, as shown in the following breakout:

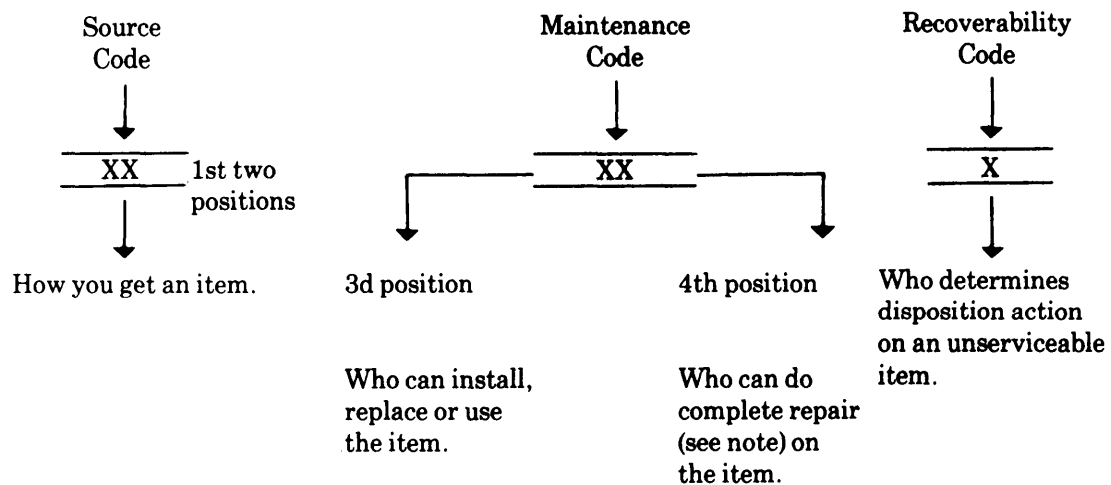

NOTE

Complete repair: Maintenance capacity, capability, and authority to perform all corrective maintenance tasks of the "Repair" function in a use/user environment in order to restore serviceability to a failed item.

(1) *Source code.* The source code tells you how to get an item needed for maintenance, repair, or overhaul of an end item/equipment. Explanations of source codes follows:

Code

Explanation

PA
PB
PC
PD
PE
PF
PG

Stocked items; use the applicable NSN to request/requisition items with these source codes. They are authorized to the category indicated by the code entered in the third position of the SMR code.

NOTE

Items coded PC are subject to deterioration.

KD
KF
KB

Items with these codes are not to be requested/requisitioned individually. They are part of a kit which is authorized to the maintenance category indicated in the third position of the SMR code. The complete kit must be requisitioned and applied.

MO—Made at org/AVUM category
MF—Made at DS/AVUM category
MH—Made at GS category
ML—Made at Specialized Repair Activity (SRA)
MD—Made Depot

Items with these codes are not to be requested/requisitioned individually. They must be made from bulk material which is identified by the part number in the description and usable on code (UOC) column and listed in the Bulk Material group of the repair parts list. If the item is authorized to you by the third position code of the SMR code, but the source code indicates it is made at a higher category, order the item from the higher category of maintenance.

AO—Assembled by org/AVUM category
AF—Assembled by DS/AVIM category
AH—Assembled by GS category
AL—Assembled by SRA
AD—Assembled by Depot

Items with these codes are not to be requested/requisitioned individually. The parts that make up the assembled item must be requisitioned or fabricated and assembled at the category of maintenance indicated by the source code. If the disposition code of the SMR code authorizes you to replace the item, but the source code indicates the item is assembled at a higher category, order the item from the higher category of maintenance.

Code

Explanation

- XA—Do not requisition an “XA” coded item. Order its next higher assembly.
- XB—If an “XB” item is not available from salvage, order it using the FSCM and part number given.
- XC—Installation drawing, diagram, instruction sheet, field service drawing, that is identified by manufacturers part number.
- XD—Item is not stocked. Order an “XD” coded item through normal supply channels using the FSCM and part number given, if no NSN is available.

NOTE

Cannibalization or controlled exchange, when authorized, may be used as a source of supply for items with the above source codes, except for those source coded “XA” or those aircraft support items restricted by requirements of AR 750-1.

(2) Maintenance code. Maintenance codes tell you the category of maintenance authorized to USE and REPAIR support items. The maintenance codes are entered in the third and fourth positions of the SMR code as follows:

- (a) The maintenance code entered in the third position tells you the lowest maintenance category authorized

to remove, replace, and use an item. The maintenance code entered in the third position will indicate authorization to one of the following categories of maintenance.

- | Code | Application/Explanation |
|------|---|
| C | Crew or operator maintenance done within organizational or aviation maintenance. |
| O | Organizational or aviation unit category can remove, replace, and use the item. |
| F | Direct support or aviation intermediate category can remove, replace, and use the item. |
| H | General support category can remove, replace, and use the item. |
| L | Specialized repair activity can remove, replace, and use the item. |
| D | Depot category can remove, replace, and use the item. |

(b) The maintenance code entered in the fourth position tells whether or not the item is to be repaired and identifies the lowest maintenance category with the capability to do complete repair (i.e., perform all authorized repair functions). This position will contain one of the following maintenance codes.

NOTE

Some limited repair may be done on the item at a lower category of maintenance, if authorized by the Maintenance Allocation Chart (MAC) and SMR codes.

- | Code | Application/Explanation |
|------|--|
| O | Organizational or aviation unit is the lowest category that can do complete repair of the item. |
| F | Direct support or aviation intermediate is the lowest category that can do complete repair of the item. |
| H | General support is the lowest category that can do complete repair of the item. |
| L | Specialized repair activity (designate the specialized repair activity) is the lowest category that can do complete repair of the item, |
| D | Depot is the lowest category that can do complete repair of the item. |
| Z | Nonreparable. No repair is authorized. |
| B | No repair is authorized, (No parts or special tools are authorized for the maintenance of a "B" coded item). However, the item may be reconditioned by adjusting, lubricating, etc., at the user category. |

(3) *Recoverability code.* Recoverability codes are assigned to items to indicate the disposition action on unserviceable items. The recoverability code is entered in the fifth position of the SMR Code as follows:

- | <i>Recoverability codes</i> | Application/Explanation |
|-----------------------------|---|
| Z | Nonreparable Item. When unserviceable, condemn and dispose of the item at the category of maintenance shown in the third position of SMR Code. |
| O | Reparable item. When uneconomically repairable, condemn and dispose of the item at organizational or aviation unit category. |
| F | Reparable item. When uneconomically repairable, condemn and dispose of the item at direct support or aviation intermediate category. |
| H | Reparable item, When uneconomically repairable, condemn and dispose of the item at general support category. |
| D | Reparable item. When beyond lower category repair capability, return to depot. Condemnation and disposal of item not authorized below depot category. |
| L | Reparable item. Condemnation and disposal not authorized below specialized repair activity (SRA). |
| A | Item requires special handling or condemnation procedures because of specific reasons (e.g., precious metal content, high dollar value, critical material, or hazardous material). Refer to appropriate manuals/directives for specific instructions. |

c. *FSCM (Column (3)).* The Federal Supply Code for Manufacturer (FSCM) is a 5-digit numeric code which is used to identify the manufacturer, distributor, or Government agency, etc., that supplies the item.

d. *Part Number (Column (4)).* Indicates the primary number used by the manufacturer (individual, company, firm, corporation, or Government activity), which controls the design and characteristics of the item by means of its engineering drawings, specifications, standards, and inspection requirements to identify an item or range of items.

NOTE

When you use a NSN to requisition an item, the item you receive may have a different part number from the part ordered.

- e. *Description and Usable on Code (UOC) (Column (5)).* This column includes the following information.
- (1) The Federal item name and, when required, a minimum description to identify the item.
 - (2) The statement "END OF FIGURE" appears just below the last item description in Column (5) for a given figure in both section II and section III.
- f. *Qty (Column (6)).* Indicates the quantity of the item used in the breakout shown on the illustration figure,

which is prepared for a functional group, subfunctional group, or an assembly. A “V” appearing in this column in lieu of a quantity indicates that the quantity is variable and the quantity may vary from application to application,

4. Explanation of Columns (Section IV)

a. National Stock Number (NSN) Index.

(1) *Stock number column.* This column lists the NSN by National item identification number (NIIN) sequence. The NIIN consists of the last nine digits of the NSN. When using this column to locate an item, ignore the first four digits of the NSN. When requisitioning items use the complete NSN (13 digits).

(2) *Fig. column.* This column lists the number of the figure where the item is identified/located. The illustrations are in numerical sequence in sections II and III.

(3) *Item column.* The item number identifies the item associated with the figure listed in the adjacent Fig. column. This item is also identified by the NSN listed on the same line.

b. Part Number Index. Part numbers in this index are listed by part number in ascending alphameric sequence.

(1) *FSCM column.* This column lists the Federal supply code for manufacturer (FSCM).

(2) *Part number column.* This column indicates the part number assigned to the item,

(3) *Stock number column.* This column lists the National stock number for the associated part number and manufacturer identified in the part number and FSCM columns to the left.

(4) *Fig. column.* This column lists the number of the figure where the item is identified/located in sections II and III.

(5) *Item column.* The item number is that number assigned to the item as it appears in the figure referenced in the adjacent figure number column.

5. Special Information

a. Associated Publications. The publication listed below pertains to the PP-7545A/U and its components: TM 11-6130-453-14, Power Supply PP-7545A/U.

b. National Stock Numbers. National stock numbers (NSN's) that are missing from P source coded items have been applied for and will be added to this TM by future change/revision when they are entered in the Army Master Data File (AMDF). Until the NSN's are established and published, submit exception requisitions to: Commander, US Army Communications-Electronics Command and Fort Monmouth, ATTN: AMSEL-MM, Fort Monmouth, NJ 07703-5006 for the part required to support your equipment.

6. How to Locate Repair Parts

a. When National stock number or part number is not known.

(1) *First.* Using the table of contents, determine the assembly group or subassembly group to which the item belongs. This is necessary since figures are prepared for assembly groups and subassembly groups, and listings are divided into the same groups.

(2) *Second.* Find the figure covering the assembly group or subassembly group to which the item belongs.

(3) *Third.* Identify the item on the figure and note the item number.

(4) *Fourth.* Refer to the Repair Parts List for the figure to find the part number for the item number noted on the figure.

(5) *Fifth.* Refer to the Part Number Index to find the NSN, if assigned,

b. When National stock number or part number is known.

(1) *First.* Using the index of National stock numbers and part numbers, find the pertinent National stock number or part number. The NSN index is in National item identification number (NIIN) sequence (para 4a(1)). The part numbers in the part number index are listed in ascending alphameric sequence (para 4b). Both indexes cross-reference you to the illustration figure and item number of the item you are looking for.

(2) *Second.* After finding the figure and item number, verify that the item is the one you're looking for, then locate the item number in the repair parts list for the figure.

7. Abbreviations

Not applicable.

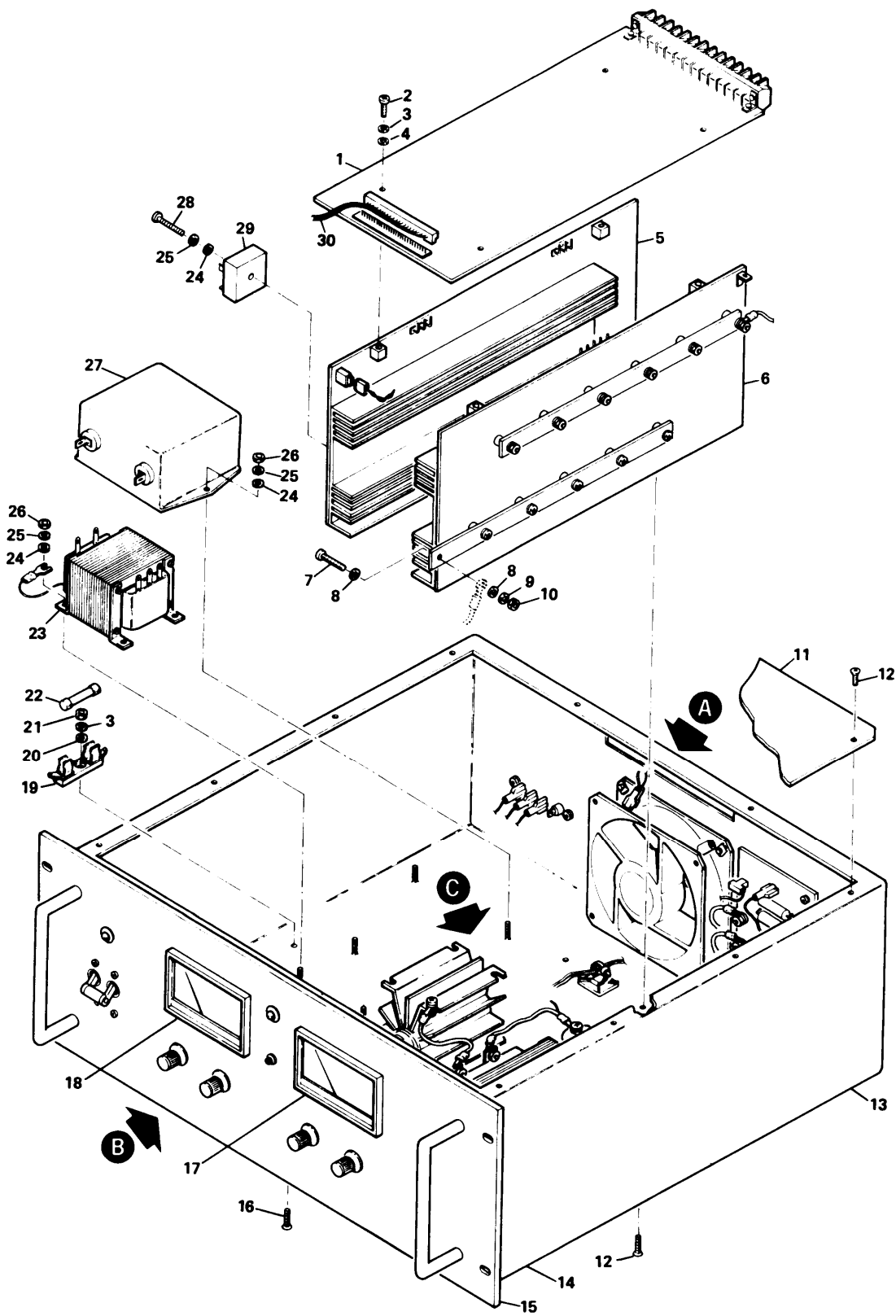

CEOBT001

Figure 1. Power Supply PP-7545A/U (Sheet 1 of 3).

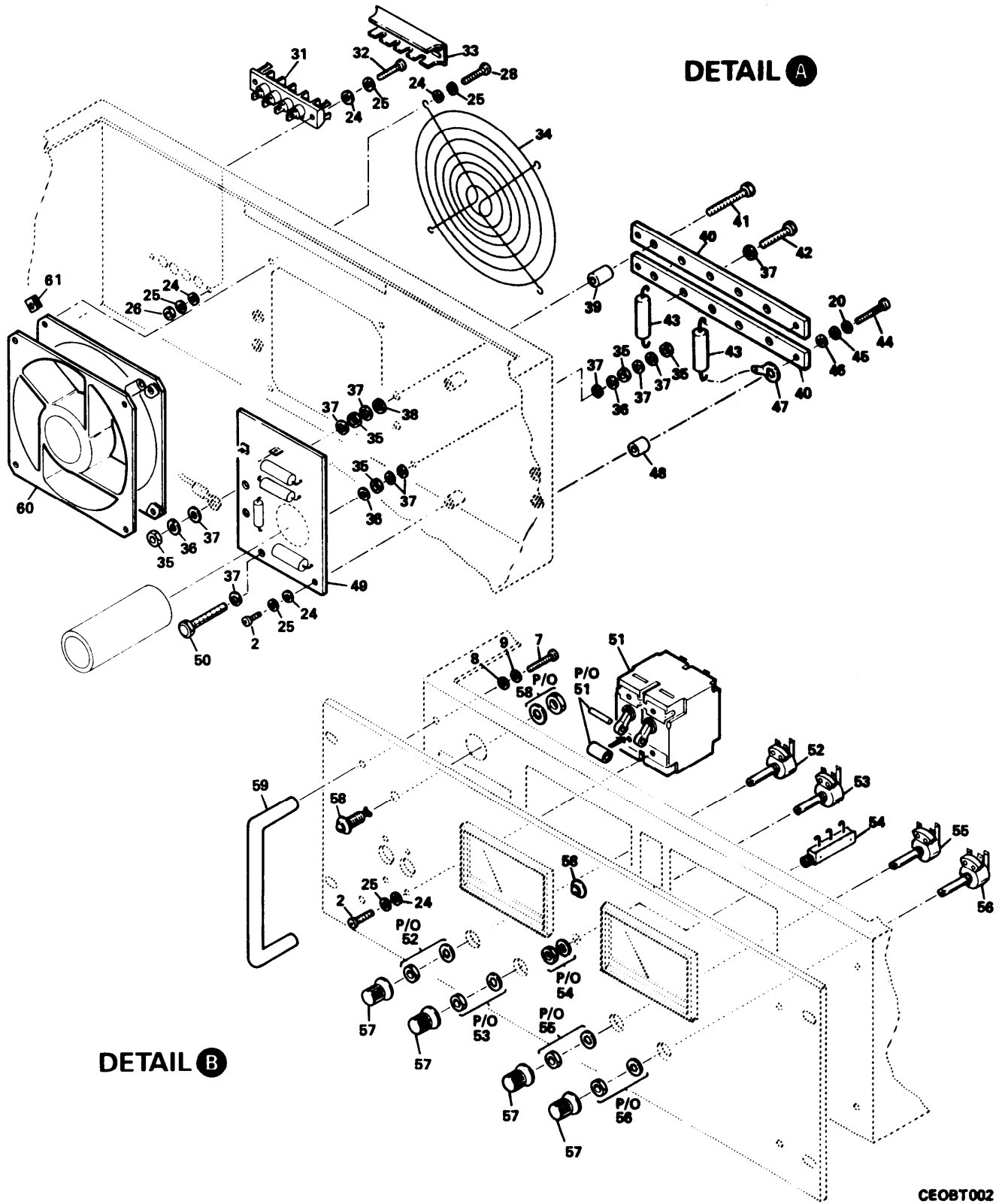

CE08T002

Figure 1. Power Supply PP-7545A/U (Sheet 2 of 3).

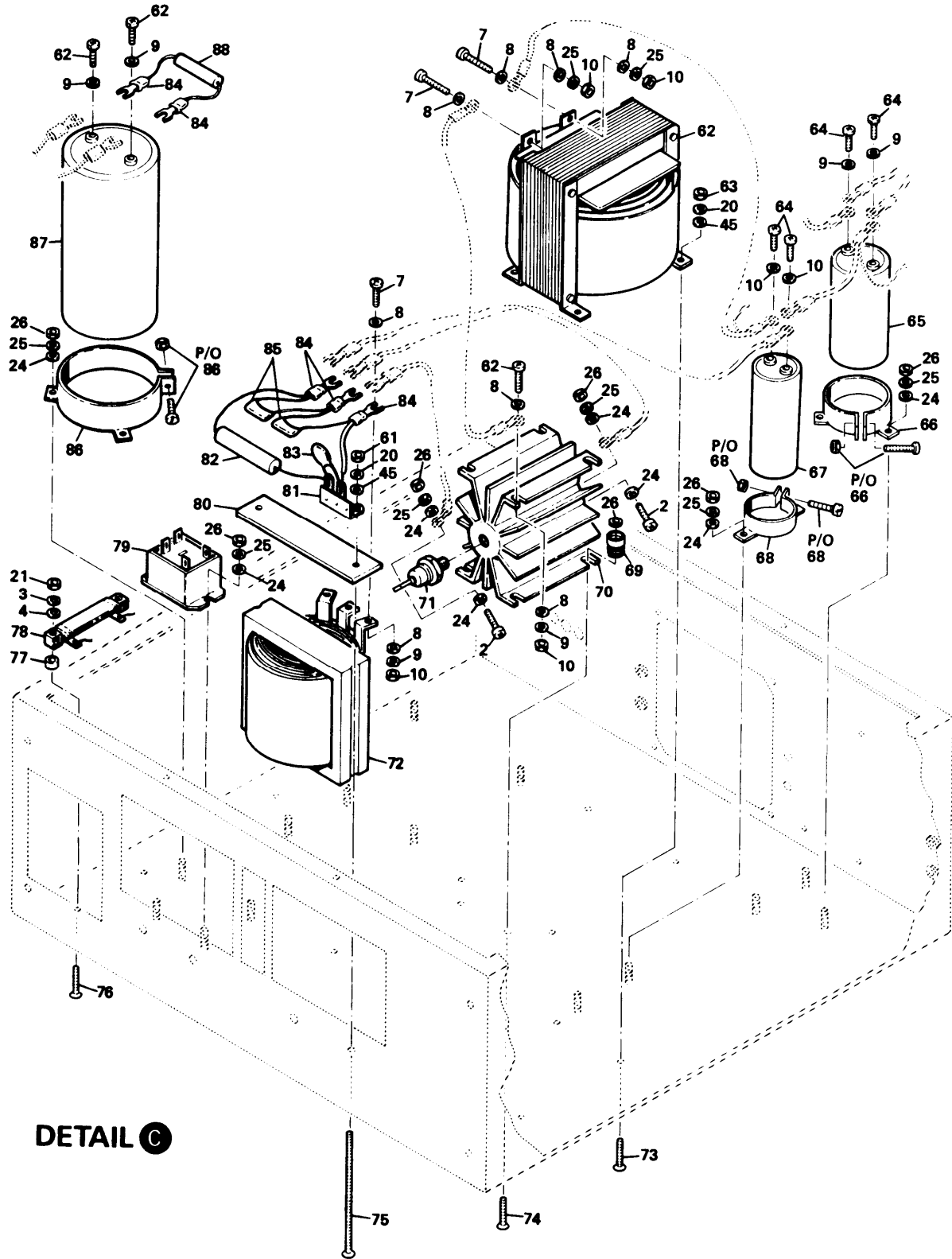

CEOBT003

Figure 1. Power Supply PP-7545A/U (Sheet 3 of 3).

SECTION II (1) ITEM NO	(2) SMR CODE	(3) FSCM	TM11-6130-453-24P (4) PART NUMBER	(5) DESCRIPTION AND USABLE ON CODE (UOC)	(6) QTY
GROUP 00 POWER SUPPLY					
PP-7545 AND					
FRONT PANEL & CHASSIS ASSEMBLY					
FIG. 1					
1	PAHZZ	61987	10-010-045-00	CKT CARD ASSY	1
2	PAHZZ	96906	MS51957-28	SCREW, MACHINE	6
3	PAHZZ	96906	MS35338-135	WASHER, LOCK	7
4	PAHZZ	88044	AN960C4	WASHER, FLAT	7
5	PAHZZ	61987	10-010-043-00	CKT CARD ASSY	1
6	PAHZZ	61987	10-010-044-00	CKT CARD ASSY	1
7	PAHZZ	96906	MS51958-63	SCREW, MACHINE	3
8	PAHZZ	80205	NAS620C10L	WASHER, FLAT	16
9	PAHZZ	96906	MS35338-138	WASHER, LOCK	17
10	PAHZZ	96906	MS35640-304	NUT, PLAIN, HEX	11
11	XBHZZ	61987	12-070-042-00	COVER, CHASSIS	1
12	PAHZZ	96906	MS51959-26	SCREW, MACHINE	18
13	PAHZZ	06383	ABMM-A	TIE, CABLE	8
14	XBHZZ	61987	12-070-041-00	CHASSIS, ELEC EQ	1
15	XBHZZ	61987	12-330-021-00	PANEL, FRONT	1
16	PAHZZ	96906	MS51957-15	SCREW, MACHINE	5
17	PAHZZ	61987	11-050-009-01	AMMETER	1
18	PAHZZ	61987	11-050-004-01	VOLTMETER	1
19	PAHZZ	71400	3998	FUSEHOLDER, BLOCK	1
20	PAHZZ	96906	MS35338-137	WASHER, LOCK	10
21	PAHZZ	96906	MS35649-244	NUT, PLAIN, HEXAGON	7
22	PAHZZ	71400	MDA-1	FUSE, CARTRIDGE	1
23	PAHZZ	61987	06-030-000-32	TRANSFORMER	1
24	PAHZZ	80205	NAS620C6	WASHER, FLAT	32
25	PAHZZ	96906	MS35338-136	WASHER, LOCK	30
26	PAHZZ	96906	MS35649-264	NUT, PLAIN, HEXAGON	25
27	PAHZZ	61987	11-180-001-00	FILTER, RFI	1
28	PAHZZ	96906	MS51957-32	SCREW, MACHINE	4
29	PAHZZ	14936	KBPC35-06	BRIDGE, RECT	1
30	XBHZZ	61987	10-020-018-00	WIRING HARNESS	1
31	XBHZZ	52458	A319304-NL	TERMINAL STRIP	1
32	PAHZZ	96906	MS51957-34	SCREW, MACHINE	2
33	XBHZZ	52458	C0-304	COVER, TERM STRP	1
34	XBHZZ	60856	9601-43	GUARD, FAN	1
35	PAHZZ	96906	MS35690-411	NUT, PLAIN, HEX	5
36	PAHZZ	61987	15-470-001-00	WASHER, LOCK	6
37	PAHZZ	88044	AN960B416	WASHER, FLAT	15
38	PAHZZ	83330	2154	WASHER, SHOULDERED	2
39	XBHZZ	06540	9259PH257	SPACER, NM	2
40	XBHZZ	61987	11-160-002-00	BUSS BAR	2
41	PAHZZ	61987	15-132-020-24	BOLT, HEX	2
42	PAHZZ	96906	MS35309-306	SCREW, CAP, HEXAGON H	2
43	PAHZZ	60935	1501K1001C	CAP, FXD, PLASTIC	2
44	PAHZZ	96906	MS51957-50	SCREW, MACHINE	2
45	PAHZZ	88044	AN960C8	WASHER, FLAT	8
46	PAHZZ	83330	2155	WASHER, SHOULDERED	2

SECTION II (1) ITEM NO	(2) SMR CODE	(3) FSCM	TM11-6130-453-24P (4) PART NUMBER	(5) DESCRIPTION AND USABLE ON CODE (UOC)	(6) QTY
47	PAHZZ	83330	1410-14	TERMINAL, LUG	4
48	XBHZZ	06540	9259PH194	SPACER, NM	2
49	PAHZZ	61987	10-010-049-00	CKT CARD ASSY	1
50	PAHZZ	61987	15-132-020-20	BOLT, HEX	1
51	PAHZZ	74193	JA2-A3-A-20-2	CIRCUIT BREAKER	1
52	PAHZZ	81349	RA10NAASD103A	RES, VARIABLE	1
53	PAHZZ	81349	RA10NAASD501A	RES, VARIABLE	1
54	PAHZZ	02111	43P104T601	RES, VARIABLE	1
55	PAHZZ	81349	RA10NAASD201A	RES, VARIABLE	1
56	PAHZZ	81349	RA10NAASD100A	RES, VARIABLE	1
57	PAOZZ	95146	PK-50B-1/8	KNOB	4
58	PAHZZ	95146	SLD-870R	LED, INDICATOR	2
59	XBHZZ	83330	2051	HANDLE, BOW	2
60	PAHZZ	60856	125XR-2281	BLOWER	1
61	XBHZZ	60856	100-13	SPEED NUT	4
62	PAHZZ	61987	06-050-017-00	INDUCTOR	1
63	PAHZZ	96906	MS35649-284	NUT, PLAIN, HEXAGON	8
64	PAHZZ	96906	MS51958-61	SCREW, MACHINE	10
65	PAHZZ	59850	FA0163G050DF1L	CAP, FXD, ELCTLT	1
66	PAHZZ	06845	A110880	RETAINER, CAPACITOR	1
67	PAHZZ	56289	36DX722G050AC2A	CAP, FXD, ELCTLT	1
68	PAHZZ	27942	VR3	RETAINER, CAPACITOR	1
69	PAHZZ	052820	107	INSULATOR, BUSHING	4
70	PAHZZ	05820	303-N-N	HEAT SINK, ELECTRICA	1
71	PAHZZ	04713	MR872	SCND DVC, DIODE	2
72	PAHZZ	61987	06-030-000-31	TRANSFORMER	1
73	PAHZZ	96906	MS51957-45	SCREW, MACHINE	4
74	PAHZZ	96906	MS51959-32	SCREW, MACHINE	4
75	PAHZZ	61987	15-110-832-72	SCREW, MACHINE	2
76	PAHZZ	96906	MS51959-19	SCREW, MACHINE	2
77	XBHZZ	83330	9017	SPACER, BRASS	2
78	PAHZZ	44655	F204	RES, FXD, WW	1
79	PAHZZ	61725	VF-12HU	RELAY, POWER	1
80	XBHZZ	61987	12-050-008-00	BRACKET, XMFR	1
81	XBHZZ	83330	829	TERMINAL, STRIP	1
82	PAHZZ	44655	20J10R	RES, FXD, WW	1
83	PAHZZ	56289	5GAD50	CAPACITOR, FIXED, CER	1
84	PAHZZ	78799	SS-32-10	TERMINAL, LUG	3
85	PAHZZ	56289	225P33392XD3	CAP, FXD, PLASTIC	2
86	PAHZZ	37942	VR12B	CLAMP, CAPACITOR	1
87	PAHZZ	59850	FA0342F400F11L	CAP, FXD, ELCTLT	1
88	PAHZZ	44655	4861	RES, FXD, WW	1

END OF FIGURE

NATIONAL STOCK NUMBER AND PART NUMBER INDEX

NATIONAL STOCK NUMBER INDEX

STOCK NUMBER	FIG	ITEM	STOCK NUMBER	FIG	ITEM
5305-00-054-5649	1	16			
5305-00-054-6652	1	2			
5305-00-054-6656	1	28			
5305-00-054-6658	1	32			
5305-00-054-6670	1	73			
5305-00-054-6675	1	44			
5305-00-059-3657	1	64			
5305-00-059-3659	1	7			
5970-00-139-4715	1	69			
5920-00-142-7439	1	19			
5910-00-151-7564	1	66			
5310-00-167-0702	1	37			
5305-00-543-5828	1	42			
5940-00-578-9896	1	47			
5310-00-582-9844	1	38			
5310-00-582-9846	1	46			
5910-00-682-2543	1	68			
5310-00-685-3744	1	45			
5305-00-727-8831	1	76			
5305-00-763-6961	1	12			
5305-00-764-0064	1	74			
5310-00-773-7624	1	24			
5310-00-781-9483	1	8			
5910-00-864-8319	1	83			
5310-00-929-6395	1	25			
5310-00-933-8118	1	3			
5310-00-933-8120	1	9			
5310-00-934-9748	1	21			
5310-00-934-9759	1	63			
5310-00-934-9761	1	26			
5355-01-028-0845	1	57			
5310-01-141-6672	1	4			
5999-01-186-3926	1	70			

NATIONAL STOCK NUMBER AND PART NUMBER INDEX

PART NUMBER INDEX

FSCM	PART NUMBER	STOCK NUMBER	FIG	ITEM
06383	ABMM-A		1	13
88044	AN960B416	5310-00-167-0702	1	37
88044	AN960C4	5310-01-141-6672	1	4
88044	AN960C8	5310-00-685-3744	1	45
06845	A110880	5910-00-151-7564	1	66
52458	A319304-NL		1	31
52458	C0-304		1	33
59850	FA0163G050DF1L		1	65
59850	FA0342F400FILL		1	87
44655	F204		1	78
74193	JA2-A3-A-20-2		1	51
14936	KBPC35-06		1	29
71400	MDA-1		1	22
04713	MR872		1	71
96906	MS35309-306	5305-00-543-5828	1	42
96906	MS35338-135	5310-00-933-8118	1	3
96906	MS35338-136	5310-00-929-6395	1	25
96906	MS35338-137		1	20
96906	MS35338-138	5310-00-933-8120	1	9
96906	MS35640-304		1	10
96906	MS35649-244	5310-00-934-9748	1	21
96906	MS35649-264	5310-00-934-9761	1	26
96906	MS35649-284	5310-00-934-9759	1	63
96906	MS35690-411		1	35
96906	MS51957-15	5305-00-054-5649	1	16
96906	MS51957-28	5305-00-054-6652	1	2
96906	MS51957-32	5305-00-054-6656	1	28
96906	MS51957-34	5305-00-054-6658	1	32
96906	MS51957-45	5305-00-054-6670	1	73
96906	MS51957-50	5305-00-054-6675	1	44
96906	MS51958-61	5305-00-059-3657	1	64
96906	MS51958-63	5305-00-059-3659	1	7
96906	MS51959-19	5305-00-727-8831	1	76
96906	MS51959-26	5305-00-763-6961	1	12
96906	MS51959-32	5305-00-764-0064	1	74
80205	NAS620C10L	5310-00-781-9483	1	8
80205	NAS620C6	5310-00-773-7624	1	24
95146	PK-50B1/8	5355-01-028-0845	1	57
81349	RA10NAASD100A		1	56
81349	RA10NAASD103A		1	52
81349	RA10NAASD201A		1	55
81349	RA10NAASD501A		1	53
95146	SLD-870R		1	58
78799	SS-32-10		1	84
61725	VF-12HU		1	79
37942	VR12B		1	86
37942	VR3	5910-00-682-2543	1	68
61987	06-030-000-31		1	72
61987	06-030-000-32		1	23
61987	06-050-017-00		1	62
61987	10-010-043-00		1	5

NATIONAL STOCK NUMBER AND PART NUMBER INDEX

PART NUMBER INDEX

FSCM	PART NUMBER	STOCK NUMBER	FIG	ITEM
61987	10-010-044-00		1	6
61987	10-010-045-00		1	1
61987	10-010-049-00		1	49
61987	10-020-018-00		1	30
60856	100-13		1	61
05820	107	5970-00-139-4715	1	69
61987	11-050-004-01		1	18
61987	11-050-009-01		1	17
61987	11-160-002-00		1	40
61987	11-180-001-00		1	27
61987	12-050-008-00		1	80
61987	12-070-041-00		1	14
61987	12-070-042-00		1	11
61987	12-330-021-00		1	15
60856	125XR-2281		1	60
83330	1410-14	5940-00-578-9896	1	47
61987	15-110-832-72		1	75
61987	15-132-020-20		1	50
61987	15-132-020-24		1	41
61987	15-470-001-00		1	36
60935	1501K1001C		1	43
44655	20J10R		1	82
83330	2051		1	59
83330	2154	5310-00-582-9844	1	38
83330	2155	5310-00-582-9846	1	46
56289	225P33392XD3		1	85
05820	303-N-N	5999-01-186-3926	1	70
56289	36DX722G050AC2A		1	67
71400	3998	5920-00-142-7439	1	19
02111	43P104T601		1	54
44655	4861		1	88
56289	5GAD50	5910-00-864-8319	1	83
83330	829		1	81
83330	9017		1	77
06540	9259PH194		1	48
06540	9259PH257		1	39
60856	9601-43		1	34

By Order of the Secretary of the Army:

JOHN A. WICKHAM JR.
General, United States Army
Chief of Staff

Official:

MILDRED E. HEDBERG
Brigadier General, United States Army
The Adjutant General

DISTRIBUTION:

To be distributed in accordance with DA Form 12-36 literature requirements for PP-7545/U.

★U.S. GOVERNMENT PRINTING OFFICE: 1964 - 342-421/81090

RECOMMENDED CHANGES TO EQUIPMENT TECHNICAL PUBLICATIONS



SOMETHING WRONG WITH THIS PUBLICATION?

THEN...JOT DOWN THE DOPE ABOUT IT ON THIS FORM. CAREFULLY TEAR IT OUT, FOLD IT AND DROP IT IN THE MAIL.

FROM: (PRINT YOUR UNIT'S COMPLETE ADDRESS)

DATE SENT

PUBLICATION NUMBER TM 11-6130-453-24P	PUBLICATION DATE 1 January 1986	PUBLICATION TITLE Power Supply PP-7545A/U
--	------------------------------------	--

BE EXACT PIN-POINT WHERE IT IS				IN THIS SPACE TELL WHAT IS WRONG AND WHAT SHOULD BE DONE ABOUT IT:
PAGE NO	PARA-GRAPH	FIGURE NO.	TABLE NO	

PRINTED NAME GRADE OR TITLE AND TELEPHONE NUMBER

SIGN HERE

DO NOT WRITE IN THESE SPACES

FILL IN YOUR
UNIT'S ADDRESS

FOLD BACK

DEPARTMENT OF THE ARMY

OFFICIAL BUSINESS

Commander
US Army Communications-Electronics Command
and Fort Monmouth
ATTN: AMSEL-ME-MP
Fort Monmouth, New Jersey 07703-5007

TEAR ALONG PERFORATED LINE

THE METRIC SYSTEM AND EQUIVALENTS

WEIGHT MEASURE

1 Centimeter = 10 Millimeters = 0.01 Meters = 0.3937 Inches
 1 Meter = 100 Centimeters = 1000 Millimeters = 39.37 Inches
 1 Kilometer = 1000 Meters = 0.621 Miles

WEIGHTS

1 Gram = 0.001 Kilograms = 1000 Milligrams = 0.035 Ounces
 1 Kilogram = 1000 Grams = 2.2 lb.
 1 Metric Ton = 1000 Kilograms = 1 Megagram = 1.1 Short Tons

LIQUID MEASURE

1 Milliliter = 0.001 Liters = 0.0338 Fluid Ounces
 1 Liter = 1000 Milliliters = 33.82 Fluid Ounces

SQUARE MEASURE

1 Sq. Centimeter = 100 Sq. Millimeters = 0.155 Sq. Inches
 1 Sq. Meter = 10,000 Sq. Centimeters = 10.76 Sq. Feet
 1 Sq. Kilometer = 1,000,000 Sq. Meters = 0.386 Sq. Miles

CUBIC MEASURE

1 Cu. Centimeter = 1000 Cu. Millimeters = 0.06 Cu. Inches
 1 Cu. Meter = 1,000,000 Cu. Centimeters = 35.31 Cu. Feet

TEMPERATURE

$5/9(^{\circ}\text{F} - 32) = ^{\circ}\text{C}$
 212° Fahrenheit is equivalent to 100° Celsius
 90° Fahrenheit is equivalent to 32.2° Celsius
 32° Fahrenheit is equivalent to 0° Celsius
 $9/5^{\circ}\text{C} + 32 = ^{\circ}\text{F}$

APPROXIMATE CONVERSION FACTORS

TO CHANGE	TO	MULTIPLY BY
Inches	Centimeters	2.540
Feet	Meters	0.305
Yards	Meters	0.914
Miles	Kilometers	1.609
Square Inches	Square Centimeters	6.451
Square Feet	Square Meters	0.093
Square Yards	Square Meters	0.836
Square Miles	Square Kilometers	2.590
Acres	Square Hectometers	0.405
Cubic Feet	Cubic Meters	0.028
Cubic Yards	Cubic Meters	0.765
Fluid Ounces	Milliliters	29.573
its	Liters	0.473
arts	Liters	0.946
allons	Liters	3.785
Ounces	Grams	28.349
Pounds	Kilograms	0.454
Short Tons	Metric Tons	0.907
Pound-Feet	Newton-Meters	1.356
Pounds per Square Inch	Kilopascals	6.895
Miles per Gallon	Kilometers per Liter	0.425
Miles per Hour	Kilometers per Hour	1.609

TO CHANGE	TO	MULTIPLY BY
Centimeters	Inches	0.394
Meters	Feet	3.280
Meters	Yards	1.094
Kilometers	Miles	0.621
Square Centimeters	Square Inches	0.155
Square Meters	Square Feet	10.764
Square Meters	Square Yards	1.196
Square Kilometers	Square Miles	0.386
Square Hectometers	Acres	2.471
Cubic Meters	Cubic Feet	35.315
Cubic Meters	Cubic Yards	1.308
Milliliters	Fluid Ounces	0.034
Liters	Pints	2.113
Liters	Quarts	1.057
ers	Gallons	0.264
ms	Ounces	0.035
ograms	Pounds	2.205
Metric Tons	Short Tons	1.102
Newton-Meters	Pounds-Feet	0.738
Kilopascals	Pounds per Square Inch	0.145
ometers per Liter	Miles per Gallon	2.354
ometers per Hour	Miles per Hour	0.621



PIN: 059376-000